

h120 HYGIENIC PUMPS

Technical Specifications



TECHNICAL SPECIFICATIONS	US	METRIC
Maximum Fluid Pressure	70 psi	4.83 bar, 0.48 MPa
Maximum Fluid Flow	120 gpm	454 lpm
Maximum Particle Size	FG (0.25 in.)	FG (6.35 mm)
	HS (0.5 in.)	HS (12.7 mm)
Environmental Temp Rating	0 to 104 °F	-18 to 40 °C
Fluid Connection	FG (2. in. Tri-Clamp)	FG (65 mm DIN 11851)
	HS (2.5 in., 3.0 in., and 4.0 in. Tri-Clamp)	HS (50 mm DIN 11851)
Suction Lift	Dry (13.3 ft)	Dry (4.0 m)
	Wet (13.3 ft)	Wet (4.0 m)
Approvals*	FDA CFR Title 21, EC 1935/2004, USP Class VI, UL, ATEX, C1D1 Group D	
Fluid Section Materials	Food Grade Stainless 316 SST, High Sanitary 316L SST, Pharma Grade 316L SST	
Surface Finish Options	FG (125 Ra), HS (32 Ra), PH (20 Ra), 3A (32 Ra)	
Seat Options	Stainless Steel	
Check Ball Options	PTFE, Santoprene, FKM, Buna, Flapper	
Diaphragm Options	2-piece PTFE, PTFE OM, Santoprene, Buna, FKM, EPDM OM	
Seals and Gasket Options	PTFE, EPDM, FKM, Buna	

*Approvals depend on the pump configuration build

ELECTRICAL RATINGS	RATED VOLTAGE	PHASE	HERTZ	CURRENT	PLUG TYPE	APPROVALS
FF1 Motor (North America)	200–240 V	3	50/60 Hz	7.5 A	NEMA L15-20	UL, Ordinary Location
FF2 Motor (World Wide)	200–240 V	1	50/60 Hz	15 A	NEMA L15-20	UL, Ordinary Location
FF3 Motor (North America)	200–240 V	3	50/60 Hz	7.5 A	Flying Leads	UL, C1D1 Group D
FF4 Motor (World Wide)	200–240 V	1	50/60 Hz	15 A	Flying Leads	UL, ATEX

QUANTM™ h120 TECHNICAL SPECIFICATIONS

PERFORMANCE AND POWER

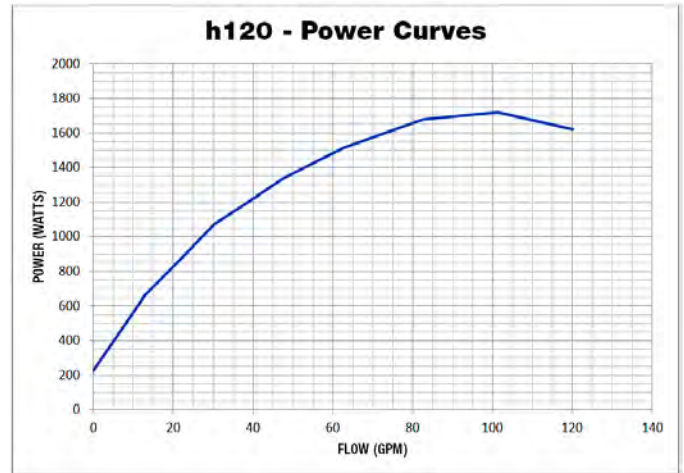
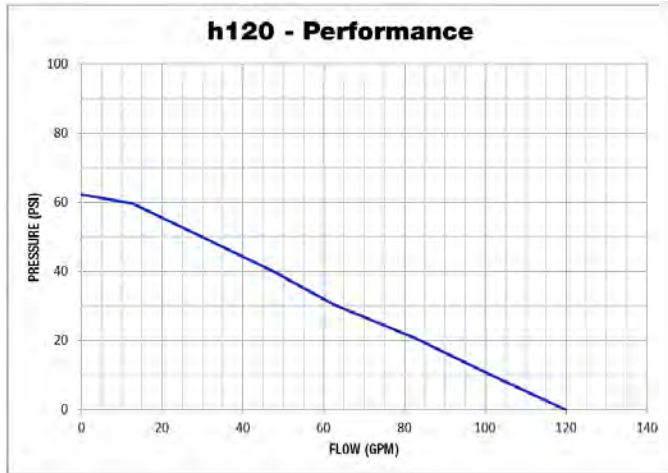

FOOD GRADE HYGIENIC

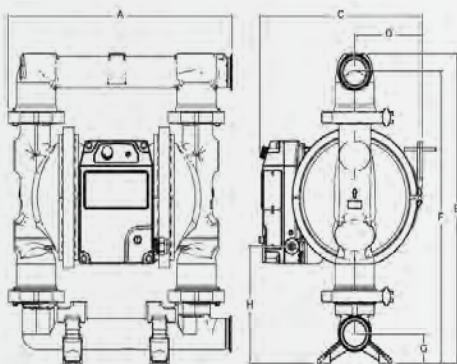

WEIGHT	
170 lb	77.1 kg

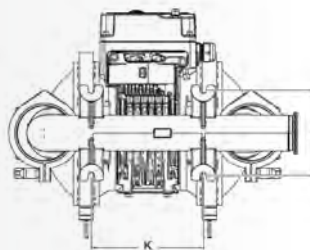

DIM REF.	IN	CM
A	21.07	53.52
B	--	--
C	15.28	38.81
D	6.33	16.08
E	25.95	65.91
F	24.40	61.98
G	2.50	6.35
H	9.82	24.94
J	6.25	15.88
K	8.16	20.73

HIGH SANITARY, PHARMACEUTICAL AND 3A HYGIENIC

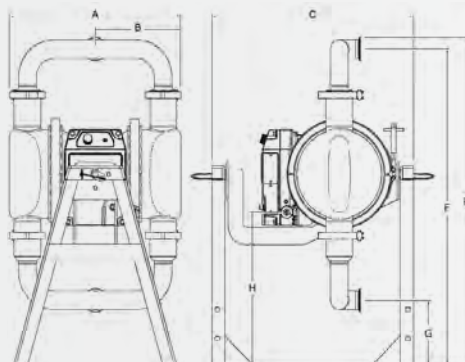

WEIGHT	
143 lb	64.9 kg

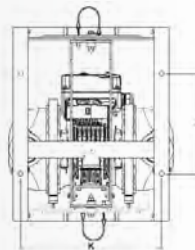

DIM REF.	IN	CM
A	19.30	49.02
B	9.65	24.51
C	14.89	37.82
D	6.33	16.08
E	35.31	89.69
F	35.05	86.49
G	7.09	18.01
H	16.10	40.89
J	16.20	41.15
K	13.00	33.02